

Technical Article Reprint From  
*Machine Design*

# Designing Ventilation Grilles for Electronic Equipment

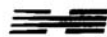

**HILL ENGINEERING**

6349 Nancy Ridge Drive, Suite A

San Diego, California 92121

858/552-1140

858/453-0668 FAX

[info@hillengineering.com](mailto:info@hillengineering.com)

# DESIGNING VENTILATION GRILLES FOR ELECTRONIC EQUIPMENT

Grille design is often a compromise of conflicting requirements for cooling capacity, safety, and EMI.

**THEODORE B. HILL**  
Hill Engineering  
San Diego, CA

**JEFFREY LIND**  
Compliance West  
San Diego, CA

Everyone knows that high temperature is the major nemesis of electronic equipment. Every 15°C rise in junction temperature of a typical semiconductor approximately doubles the failure rate of that component. It's no wonder, then, that thermal analysis and cooling system design should be a major part of electronic equipment design.

However, designers of this equipment are faced with a dilemma. Free, unrestricted air flow is the best and least expensive way to remove heat from electronic components. But parts must be encased in enclosures to protect them from the environment, guard personnel from shocks, and prevent electromagnetic interference with surrounding equipment. This interferes with the free flow of air over components, and temperatures inside enclosures can rise to levels that endanger the electronics.

As a compromise, enclosures normally include some type of ventilation openings that permit some

flow of air over components. Openings come in many variations such as louvers, slots, holes, and screens. But opening selection and design is not just a matter of styling. Serious concerns about cooling capacity, safety, and electromagnetic inter-

ing fluid moving across a surface. In natural convection, the driving force moving the fluid is the buoyancy caused by thermal expansion; that is, hot air rises. The fluid most commonly used in electronic cooling is air because it is abundant, nontoxic, and clean. Other fluids such as water and freon are used occasionally if extremely high power dissipation or localized hot spots must be handled.

Both sealed and ventilated enclosures can be cooled by natural

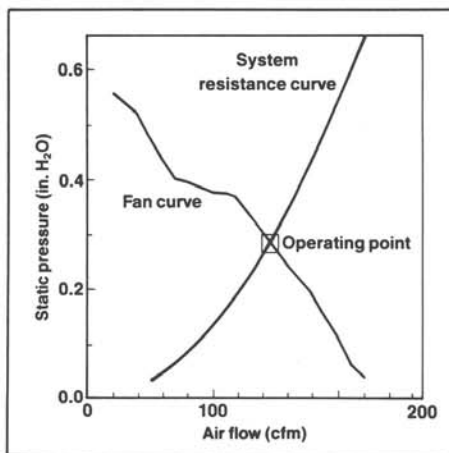

*Fan curve shows air-mover performance, and the system resistance curve shows the pressure drop to create air flow through an enclosure. The point where they intersect is the flow and static pressure for a particular fan/enclosure combination.*

convection. However, heat removal from a sealed enclosure is limited by the lack of effective heat transfer paths from hot internal components to exterior surfaces. In a sealed enclosure, internal temperature rise is inversely proportional to the external surface area available for convection.

If enclosure surface area is limited, ventilation holes can be used to improve heat transfer. Ventilated enclosures can be cooled by natural convection if heat concentration in the enclosure is below

ference come into play when designing a ventilation grille. These considerations often conflict, and the final selection is often a balance of all three requirements.

## Cooling

In a typical enclosure, heat is transferred by convection to a cool-

## VENTILATION GRILLES

about 0.15 W/in.<sup>3</sup> Additionally, circuit boards should have power dissipation below about 0.12 W/in.<sup>2</sup> to maintain acceptable temperatures. Forced-air cooling generally is required if these values are exceeded.

Grille area is critical in an enclosure cooled by natural convection. Even in well-designed enclosures, inlet and exhaust grilles each typically contribute about one-third of the pressure drop cre-

ated by the air movement through the enclosure.

A rough estimate of inlet and outlet grille area, in.<sup>2</sup>, can be made from  $A_i = 0.3 \frac{Q}{\rho_A + \rho_i} \sqrt{\frac{T_i + 460}{h \Delta T^3}}$

### PERFORATED METAL AND METAL SCREEN FOR VENTILATION GRILLES

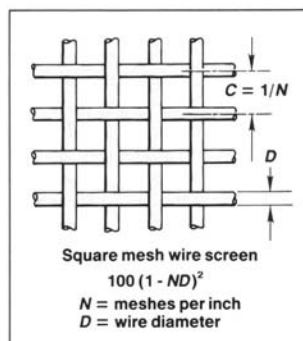
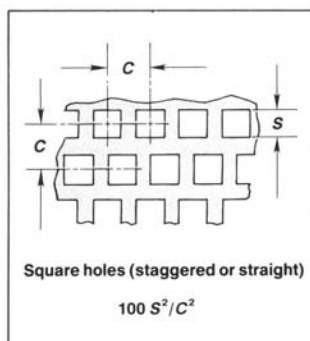
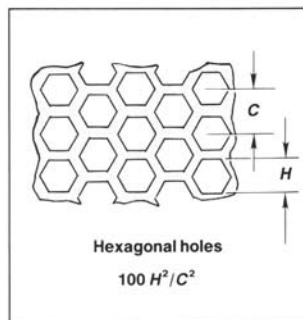
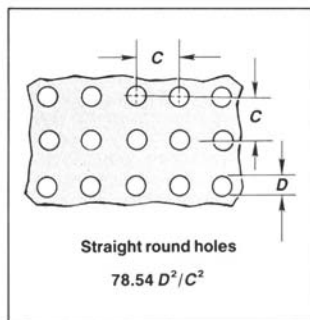
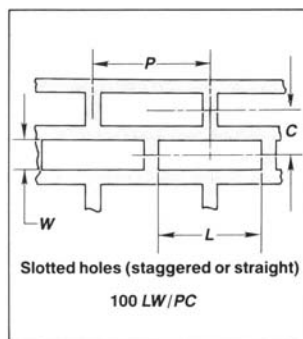
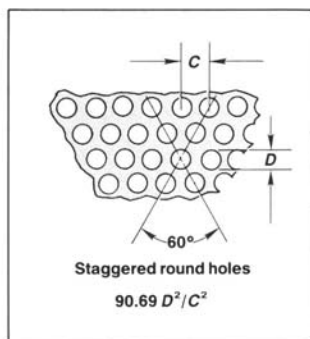

Perforated metal is available in round, square, and hexagonal holes as well as rectangular slots. Holes may be on straight centers or staggered to allow closer packing of holes and greater open area. The Industrial Perforators Association (Milwaukee, WI) has standardized a number of hole patterns.

Perforated metal thickness is limited by the punched hole size. In carbon steel and aluminum, sheet thickness cannot exceed the minimum hole diameter. In harder materials, such as stainless steel, thickness should be at least one gage thinner than the minimum hole diameter. Open area, as percentage of total area, can range from 2 to 80%, although 60% is the practical maximum.

Metal screen materials range from copper and brass to stainless steel with open areas from 10 to 70%. Mesh sizes with openings down to 0.001 in. are available.

#### Dimensions and open area of IPA standard perforations

IPA Number	Hole Size (in.)	Center Distance (in.)	Open Area (%)
<b>60 degree staggered round holes</b>			
106	1/16	1/8	23
107	5/64	7/64	46
108	5/64	1/8	35
109	3/32	5/32	33
110	3/32	3/16	23
111	3/32	1/4	13
112	1/10	5/32	37
113	1/8	3/16	40
114	1/8	7/32	30
115	1/8	1/4	23
116	5/32	7/32	46
117	5/32	1/4	35
118	3/16	1/4	51
119	3/16	5/16	33
120	1/4	5/16	58
121	1/4	3/8	40
122	1/4	7/16	30
123	1/4	1/2	23
<b>Square holes</b>			
200	2/10	1/4	64
201	1/4	3/8	44
<b>Slotted holes</b>			
207	1/8 × 3/4		41
208	1/8 × 1		43

$$A_o = A \frac{T_i + 460}{T_A + 460}$$

Where  $Q$  = heat dissipation inside the enclosure, W;  $\rho_A$  = ambient air density, lb/ft<sup>3</sup>;  $\rho_i$  = air density inside the enclosure, lb/ft<sup>3</sup>;  $h$  = height difference between inlet and outlet grilles, ft;  $\Delta T$  = required air temperature rise, °F. Ambient temperature  $T_A$ , and the preferred temperature inside the enclosure  $T_i$  must be known. Outlet area is larger than inlet because air expands as it warms; therefore, a larger outlet grille is required to maintain air flow while limiting velocity. For high-altitude operation, open area must be increased to compensate for the reduced air density.

The air flow path should be designed to minimize sharp turns and restrictions. Also, hot components should be placed near the outlets. The flow path must have a clear route, and trapping air in horizontal chambers should be avoided.

The equations are approximate, are valid only for air temperature of 0 to 150°F, and should be used only for guidance to design an enclosure using natural convection cooling. Prototypes should always be tested to verify that the design temperature rise is not exceeded. Computer programs and consulting services are available to help design and test natural convection cooled enclosures.

In forced convection, a fan or blower creates a pressure gradient causing air flow. The air flow  $F$  to cool an enclosure at standard conditions is

$$F = 3.16 \frac{Q}{\Delta T}$$

For lower density air, flow must be increased proportionally. Typical electronic equipment specifications limit air temperature rise to 18 or 20°F (10 or 11°C).

Airmover performance is described by a fan curve, which plots static pressure vs. air flow. At high flows, little pressure is available; at high pressures, low flows are available. A system resistance curve shows the pressure drop required for a given air flow through a par-

ticular device. The system resistance curve takes the form

$$P = kF^n$$

where  $P$  = static pressure and  $k$  = constant. Exponent  $n$  ranges from 1.8 to 2 depending on equipment design.

Static pressure generated by a known air flow is measured to determine the resistance curve for a system. However, this measurement requires test equipment usually available only in specialized air flow laboratories.

The intersection of the fan curve and the system resistance curve is the system operating point. This indicates the flow and static pressure reached by a particular fan and enclosure.

$$V = F/A$$

where  $A$  = duct cross-sectional area, ft<sup>2</sup>;  $F$  = volume flow rate; and  $V$  = average air velocity, fpm. Pressure drop through a perforated grille or metal screen is

$$\Delta p = K_t (\frac{1}{2} \rho V^2)$$

Pressure drop coefficient  $K_t$  varies with open area. Metal screens create a lower pressure drop for a given open area than perforated grilles because of their smoother edges. A simplified equation for air at standard conditions is

$$\Delta p = 1.29 (10^{-3}) K_t \left( \frac{F}{A^*} \right)^2$$

where  $A^*$  = grille impact area, in.<sup>2</sup>, and  $\Delta p$  = pressure drop, in. H<sub>2</sub>O. Impact area is total grille area, not just open area.

If the air flow contracts suddenly at the same point as the grille, an additional factor must be added to the  $K_t$  factor. For inlet grilles mounted on the enclosure surface, 0.50 should be added to the chart value for  $K_t$ .

Pressure drop through louvers can be roughly estimated based on open area, using the grille method. Pressure drop will always be greater for louvers than perforated material because of momentum

lost in turning the air. Designs should be tested to verify expected pressure drops.

To reduce pressure drops through an enclosure, the open area percentage and total area of ventilation openings should be increased. Sharp turns, air flow re-

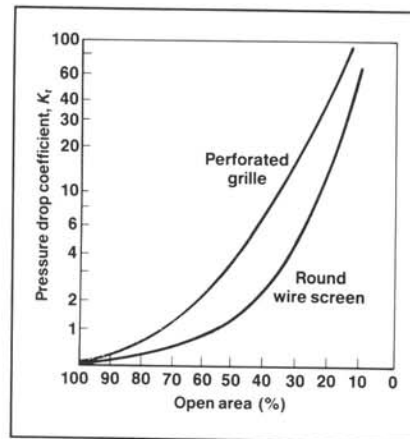

Source: SAE, Aerospace Applied Thermodynamics Manual

strictions, and the number of air flow direction changes should be minimized.

Initially, grille open area, in.<sup>2</sup>, is sized to limit maximum air velocity through the openings to 400 fpm, using

$$A \geq 0.36 F$$

## Electromagnetic interference

EMI includes electromagnetic energy radiated from computers and other microprocessor-controlled equipment. The interference can cause problems with adjacent equipment by generating electrical noise and unwanted information signals. EMI may leave (or enter) equipment through power lines, system interconnect cables, or directly through openings in the enclosure.

EMI can cause more problems than simple radio interference. Operation of automated equipment or other sophisticated electronics may be affected.

Because of unwanted computing equipment interaction with broadcast equipment, the Federal Com-

## VENTILATION GRILLES

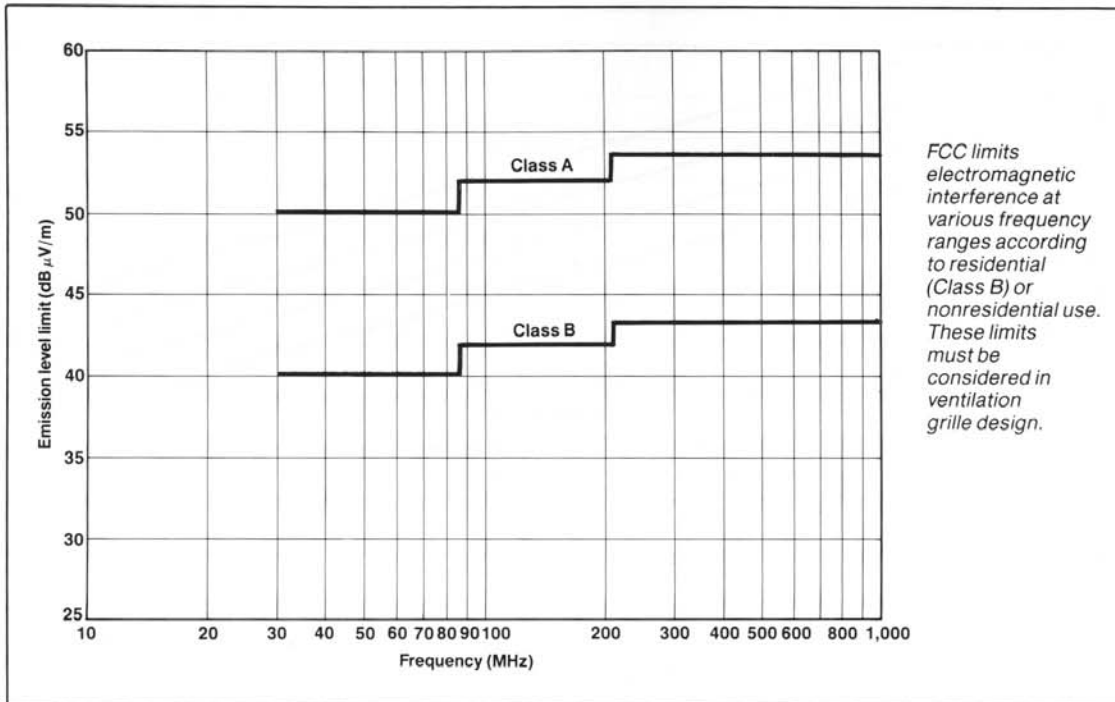

munications Commission (FCC) mandated frequency limits on such devices. Canada, Germany, Japan, and the European Standards Harmonization Organization (CENELEC) have similar but slightly different rules and regulations.

Conducted EMI can be reduced with line filters. Radiated EMI is diminished by using lower clock speeds, decoupling signal lines with capacitors, and using ground planes in printed circuit boards. Even with this source reduction, most designs will need some quieting of radiated EMI. Ventilation holes, while providing open cooling areas, must be designed carefully to reduce EMI.

FCC mandates quieting up to 1 GHz for commercial equipment. These usually do not have excessive radiation above 200 MHz. Generally, 30-dB quieting will allow a design to pass FCC Part 15 requirements. As a guideline, any opening's major axis should be less than one-twentieth of a wavelength of the assumed highest problem frequency  $f$ , in MHz. Too large an opening could act as a slot antenna. Wavelength  $\lambda$  is

$$\lambda = 29,972/f$$

If wavelength is large relative to slot length  $d$ , and slot length is large relative to the metal enclosure thickness, signal attenuation  $R$  is

$$R = 20 \log (\lambda/2d)$$

The major axis should be no longer than about 2.5 cm for a theoretical 40 dB quieting at 200 MHz. Openings placed closer than one-half wavelength, 75 cm at 200 MHz, will

cause a slight reduction in shielding effectiveness.

Ventilation openings should be as far from radiation sources as possible. If source to opening distance is shorter than the opening's major axis, shielding effectiveness will be further reduced.

Some designs may require slots larger than the suggested maximum. In these cases, metal screens can be used to break the area into smaller sections. However, screen

### Shielding effectiveness for various perforations

Hole diam (in.)	60° Center spacing (in.)	% Open area	Thick-ness (in.)	Mat'l	Shielding effectiveness (dB)			
					30MHz	100MHz	300MHz	1GHz
0.055	0.093	31	0.050	Al	68	79	78	75
0.065	0.109	32	0.050	Al	62	70	65	67
0.062	0.125	23	0.025	Al	61	71	59	61
0.068	0.250	6.7	0.060	Al	66	79	78	78
0.078	0.125	34.4	0.050	Stl	61	72	64	62
0.100	0.1875	25.9	0.040	Al	58	70	62	56
0.125	0.1875	40	0.032	Al	48	56	48	46
0.125	0.1875	40	0.060	Stl	53	64	49	53
0.125	0.1875	40	0.125	Al	66	68	64	66
0.125	0.250	22.5	0.040	Al	56	68	56	54
0.156	0.1875	63	0.036	Stl	42	46	39	38
0.156	0.218	46	0.050	SS	49	56	46	45
0.1875	0.250	50	0.060	SS	47	50	44	42
0.1875	0.375	22.5	0.040	Al	50	58	50	46
0.1875	0.500	12.8	0.040	Al	56	69	56	52
Dynamic range of test system					70	79	80	94

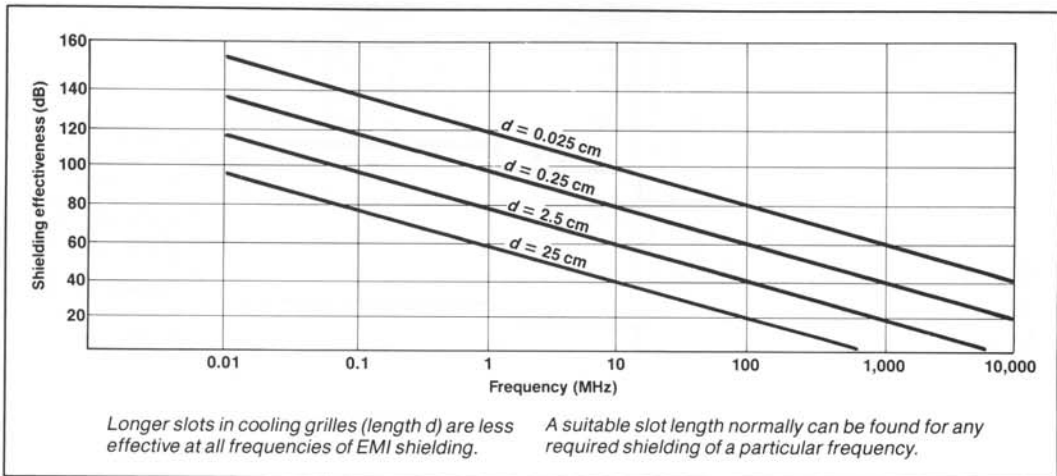

material should be chosen carefully, because corrosion between dissimilar metals will deteriorate the ground connection of the screen, limiting its shielding. Good contact at screen wire intersections also is important. Variations in wire size, hole opening, weave quality, and screen-to-enclosure bonding method make prototype shielding tests important. Perforated metal, with holes smaller than slots, can be used closer to radiation sources without degrading shielding effectiveness.

To shield frequencies higher than 200 MHz, slot size should be reduced using the  $\lambda/20$  guideline. A waveguide construction can provide greater shielding. A honeycomb construction, with opening depth four times the width, yields almost 90 dB shielding at 5 GHz.

### Safety

Ventilation openings are viewed as potential hazards by safety agencies worldwide. Openings allow unintended access to mechanical and shock hazards and can allow foreign objects to enter and bridge different voltage potentials. Therefore, opening dimensions are closely controlled.

Although each country's approval agency has differing requirements, most of the world follows one of two paths in determining what is safe. The U.S., Canada, and Japan use standards similar to Un-

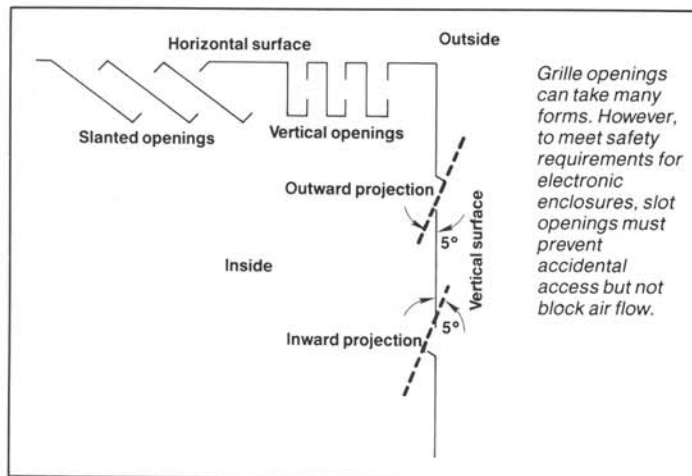

derwriters Laboratories (UL) standards; the Common Market and Nordic countries follow standards based on the standards of the International Electrotechnical Commission (IEC).

Ventilation openings that shield voltages over 30 V or greater than 240 VA are subject to agency scrutiny. Also, bottom holes generally are discouraged and subject to special requirements, and openings on horizontal surfaces must deflect a falling object away from exposed hazardous voltages. Alternatively, openings may be smaller than 5 mm in any dimension. UL accepts 1-mm slots of any length.

Vertical surface ventilation

openings must meet the same requirements. Louvers may be used instead of perforated holes, but EMI (longer major axis) and airflow resistance must be considered.

Plastic enclosures present additional safety problems, including impact and flammability requirements. Grilles are a specific impact test concern. Also, to comply with EMI requirements, a conductive coating sometimes is applied to a plastic enclosure's interior. These coatings may chip, flake, or peel, possibly bridging live parts and causing a safety hazard. These coating/plastic combinations have not received general approval from safety agencies. ■